

7.5. General arguments

7.5.0. Overview

We have answered questions about entailment concerning truth-functional compounds by turning them into questions about their immediate components (or sentences contradictory to them). The largest component formulas of sentences formed by quantifiers usually contain free variables, so we will look at the sentences that are the result of putting closed terms in place of these variables.

7.5.1. Conjunction and universal quantification

An unrestricted universal sentence behaves like a conjunction of sentences saying of each particular thing what the universal says of everything.

7.5.2. Instantiation

The laws of entailment for unrestricted universals treat them as conjunctions of their instances for particular things. However, a universal behaves like a conjunction with indefinitely many conjuncts: it entails each of its instances but cannot be replaced by them.

7.5.3. Generalization

The instances of a universal are all predications of the same abstract, and this makes it possible to establish a universal by way of a single “typical” instance.

7.5.4. Adding instances

Because a universal has indefinitely many instances, we cannot consider each in a derivation. Instead, we exploit a generalization only partially to extract those instances that are relevant to the argument we are considering.

7.5.5. General arguments in derivations

To insure that we establish an instance of a universal in a way that admits generalization, we construct it for a new term that is permitted only a limited scope in the generalization.

7.5.6. Syllogisms

The rules for the unrestricted universal enable us to establish, among other things, the validity of arguments from a special class traditionally labeled “syllogisms” (in a narrow sense of the term).

Glen Helman 28 Aug 2008

7.5.1. Conjunction and universal quantification

The truth conditions of generalizations are analogous to those of conjunctions. So, before looking at laws and rules for the universal quantifiers, we will spend some time comparing these operations to conjunction.

Consider the pair of sentences analyzed below.

Every permanent member of the Security Council supported the resolution

$(\forall x: Mx) Sx$

Britain, China, France, Russia, and the U. S. supported the resolution

$Sb \wedge Sc \wedge Sf \wedge Sr \wedge Su$

M: [_ is a member of _]; S: _ supported _ ; b: Britain; c: China; f: France; l: the resolution; r: Russia; s: the Security Council; u: the U. S.

These two sentences have the same truth value, but they are not equivalent because in a different possible world the membership of the Security Council could be different.

However, consider the sentence

Each of Britain, China, France, Russia, and the U. S. supported the resolution

This could be analyzed in the same way as the second sentence above, but it could be analyzed also as a restricted universal whose restricting predicate is [_ is Britain, China, France, Russia, or the U. S.]—switching to **or** here for the same reasons that lead to us switch in handling **all boys and girls** (see 7.3.2). A full analysis would give us the following:

$(\forall x: x=b \vee x=c \vee x=f \vee x=r \vee x=u) Sx$

And this universal *is* equivalent to the conjunction because either way we say that the predicate [_ supported] is true of the reference values of b, c, f, r, and u.

Each of the universals $(\forall x: \rho x) \theta x$ and $\forall x \theta x$ says that the predicate θ is true of each value in the domain over which it generalizes. Only in special cases (like the example just above) will either be equivalent to a conjunction

$\theta\tau_1 \wedge \theta\tau_2 \wedge \dots \wedge \theta\tau_n$

that predicates θ of each of a series of terms. But it can still be enlightening to compare universals to such conjunctions, so we will develop some vocabulary for doing so. We will do this only for unrestricted universals since it is those that we will focus on in derivations.

Let us say that an *instance for* a term τ of a universal $\forall x \theta x$ is a sentence $\theta\tau$ that applies the quantified predicate θ to τ —that is, an instance of a universal $\forall x \dots x \dots$ has the form $\dots \tau \dots$, the result of putting τ in place of the

occurrences of that variable x that are bound to the quantifier $\forall x$. An instance asserts of a single reference value what the universal asserts of everything in its domain.

If every reference value is the extension of some term, an unrestricted universal $\forall x \theta x$ will be true if and only if each of its instances $\theta \tau$ is true. This means that it will behave like a conjunction of these instances. But this is not to say that we could work with such a conjunction in place of the universal because, given just one unanalyzed term and one functor, there will be infinitely many compound terms and infinitely many instances of any universal whose quantifier actually binds a variable. For example, given an unanalyzed term a and functor f , the language will contain the terms

$a, fa, f(fa), f(f(fa)), \dots$

and a universal $\forall x Px$ will have the instances

$Pa, P(fa), P(f(fa)), P(f(f(fa))), \dots$

Although it is possible to make sense of infinite conjunctions if there is no expectation that it be possible to write them down, our references to conjunctions of all instances will be only a figure of speech used to motivate and guide our treatment.

For an unrestricted universal to behave like a conjunction of its instances, every reference value must be the value of some term. So let us develop the figure of speech further by imagining that the ID of each reference value in a range \mathbf{R} is added as a further term of our language. We will speak of this operation as *expansion by \mathbf{R}* . If we expand the language by the range \mathbf{R} of a structure, an unrestricted universal $\forall x \theta x$ will be true in that structure if and only if all its instances are true.

Glen Helman 28 Aug 2008

7.5.2. Instantiation

The special features of the laws of entailment we will state for the universals can be traced to two sources. One is the analogy with conjunction we have just explored. The other is a pair of differences between what we have said about universals and what we may say about ordinary conjunctions.

The first difference lies in the fact that the principles of entailment for universals must hold for all structures, so they cannot depend on special assumptions about the range \mathbf{R} of reference values. This means, in particular, that the set of “components” of a universal (i.e., its instances in an expansion by \mathbf{R}) must be left indefinite while an ordinary conjunction has a definite and, indeed, finite set of components. This would make universals difficult to deal with were it not for their second difference from conjunctions. The components of an ordinary conjunction can be any pair of sentences so they need have nothing in common, and we must consider them individually; but the instances of a universal all follow the same pattern, differing only in occurrences of a single term, so we can speak of them all together by speaking of this pattern. We will look at the effects of this second difference more closely in the next subsection when we consider the role of universals as conclusions. For the moment, we will concentrate on their role as premises.

We will develop laws for universals by taking certain laws for conjunctions as our model and modifying them to take account of the differences just outlined. In considering universals as premises, the laws for conjunction we will work from are the following:

$$\phi \wedge \psi \Rightarrow \phi$$

$$\phi \wedge \psi \Rightarrow \psi$$

Although these principles are clearly associated with the rule of Extraction, they are less far reaching than our law for conjunction as a premise. The fact that we focus on them is due to the first difference between universals and conjunction: the law for conjunction as a premise says we can replace a conjunction by its components, but there is no hope of doing anything like this for a universal since it has no one definite set of instances.

When taken together, these laws say that a conjunction implies each of its components. The analogous claim about an unrestricted universal is that it implies each of its instances. This is a principle known as *universal instantiation*:

$$\forall x \theta x \Rightarrow \theta \tau \text{ for each term } \tau$$

Or, using an alternative notation, $\forall x \dots x \dots \Rightarrow \dots \tau \dots$. For example, the sentence *Everything is fine and dandy* implies the claim *The weather is fine*

and dandy as well as other sentences of the form τ is fine and dandy.

The principle of universal instantiation is not quite what we will take as our account of the unrestricted universal as a premise. Universal instantiation can be used along with the law of lemmas to develop a derivation by adding any instance of a universal premise as a further resource.

LAW FOR THE UNRESTRICTED UNIVERSAL AS A PREMISE. $\Gamma, \forall x \theta x \Rightarrow \phi$ if and only if $\Gamma, \forall x \theta x, \theta \tau \Rightarrow \phi$ (for any set Γ , sentence ϕ , predicate θ , and term τ)

Since the **only if** part of this claim follows from the monotonicity of entailment, the key property of the universal lies in the **if** part: an argument with a universal as a premise is valid if the result of adding an instance as a further premise is valid. That is, when establishing the validity of an argument with universal premise, we are free to add any instance as a further premise. Note that the instance is added as a *further* premise. This is required for the **only if** part to be true. We cannot drop the universal because we cannot expect its content to be exhausted by a single instance; **Everything is fine and dandy**, for example, has implications for things other than the weather. As you might expect, our inability to drop the universal from the premises will some cause complications when we try to implement this law in derivations.

We will not be considering derivations for restricted quantifiers in their own right. Arguments involving them can be captured by way of their restatements using unrestricted quantifiers, and the principles governing these quantifiers can be derived directly from those governing the unrestricted quantifiers and the conditional. For example, in the case of the restricted universal as a premise, we have the following

$\Gamma, (\forall x: \rho x) \theta x \Rightarrow \perp$ if and only if both $\Gamma, (\forall x: \rho x) \theta x \Rightarrow \rho \tau$ and $\Gamma, (\forall x: \rho x) \theta x, \theta \tau \Rightarrow \perp$

$\Gamma, (\forall x: \rho x) \theta x, \rho \tau \Rightarrow \phi$ if and only if $\Gamma, (\forall x: \rho x) \theta x, \rho \tau, \theta \tau \Rightarrow \phi$

$\Gamma, (\forall x: \rho x) \theta x, \neg^{\pm} \theta \tau \Rightarrow \phi$ if and only if $\Gamma, (\forall x: \rho x) \theta x, \neg^{\pm} \rho \tau, \neg^{\pm} \theta \tau \Rightarrow \phi$

The first is the key principle. It reflects aspects of the laws for unrestricted universals and for conditionals as premises. It is from the latter that it derives its restriction to *reductio* arguments. Notice that the two entailments on the right show that the term τ refers to a counterexample to the derivation, with the first showing that it is in the domain and the second reducing to absurdity the claim that it has the attribute. The other two principles reflect aspects of the *modus ponens* and *modus tollens*: if we know that τ refers to something in the domain of a generalization whose truth we are assuming, we can add the assumption that this thing has the attribute and, if we know that it does not have the attribute, we can add the assumption that it is not in the domain. In short, there are three key ways to use a restricted universal assumption: to reduce to

absurdity any assumption that something is a counterexample, to show that something has its attribute (when it is assumed to be in the domain), and to show that something is not in the domain (when it is assumed not to have the attribute).

Glen Helman 28 Aug 2008

7.5.3. Generalization

Next let us look at the role of an unrestricted universal as a conclusion. Here we have the law for conjunction as a conclusion to use as a model.

$$\Gamma \Rightarrow \varphi \wedge \psi \text{ if and only if } \Gamma \Rightarrow \varphi \text{ and } \Gamma \Rightarrow \psi.$$

We have to expect changes, though, because that law gives separate consideration to each of the two components of the conjunction and we cannot expect to do this for the instances of a universal. Still, the law for conjunction points us in the right direction: we should look for some way of connecting the validity of a universal conclusion with the validity of arguments having its instances as conclusions.

A connection like this is used in geometric proofs when we begin by saying, for example, “Let ABC be a triangle,” and then go on to use our conclusions concerning ABC to justify general conclusions about all triangles. That is, we sometimes establish universal claims by *generalizing* from particular instances of them.

Clearly not every generalization from a particular instance will be legitimate. Certain premises may entail *The Empire State Building is tall* without entailing *Every building is tall*. In a geometric argument concerning a triangle ABC , we limit the information that we may use about the instance that we are considering to what we may establish concerning any triangle. For example, we ignore the fact we are using a diagram that shows ABC as acute or obtuse, and we probably avoid drawing it as a right triangle or an isosceles triangle to begin with. These restrictions are sometimes expressed by saying that we are arguing about an *arbitrary* or an *arbitrarily chosen* triangle. The idea is that what you say about the triangle ABC should hold for a triangle chosen at random or even one chosen by your worst enemy. Let us call an argument like this a *general argument* since it argues for an instance in a way that will hold generally for values in the domain of a universal.

The law we are looking for should say that an unrestricted universal is a valid conclusion from given premises if we can establish an instance of it by a general argument. But we need to make this more precise. In particular, we need to say how we can recognize a general argument just by looking at the logical forms of the sentences it involves.

If we were to give instructions for making a general argument about a triangle ABC , one thing we might say is that we should not use any special assumptions about ABC . If we are going to generalize about triangles, we may assume that ABC is a triangle but we should not assume that it is acute or obtuse. This is just another way of saying that we should not use special

information about this triangle, but it suggests an idea we can apply to arguments when we know only their logical forms. Since we are considering arguments for unrestricted universals, we must be able to generalize not just about triangles, or some other limited class, but about everything; and that means we should use no assumptions at all about the term from which we wish to generalize. To insure that we do not use any special assumptions about a term τ when we generalize from an instance $\theta\tau$ to a universal $\forall x \theta x$, we will require that τ not appear in our assumptions. For reasons we will consider in 7.6.1, we will require also that τ not appear in the predicate θ and that it be unanalyzed so that it not only does not appear in the assumptions or θ but in fact shares no vocabulary with them.

Even setting aside these further requirements, you may have noticed a couple of jumps here. Saying we have an assumption containing τ is different from saying we have used that assumption, and saying that τ appears in an assumption is different from saying that the assumption provides special information about τ . For example, *The weather is fine and dandy and so is everything else* mentions the weather without constituting a *special* assumption about it (since the same assumption is made about everything). Still, the requirement that the term from which we generalize not appear in the assumptions is easy to check and using it will not limit the entailments we can establish, only the terms we can use to establish them.

These restrictions appear in our law stating the conditions under which a universal can be validly concluded.

LAW FOR THE UNRESTRICTED UNIVERSAL AS A CONCLUSION. $\Gamma \Rightarrow \forall x \theta x$ if and only if $\Gamma \Rightarrow \theta\alpha$ (for any set Γ and predicate θ and any unanalyzed term α that appears in neither Γ nor θ)

Let us say that an unanalyzed term appearing in neither the premises or conclusion of an argument is *independent* with respect to that argument. In this vocabulary, the law says that an argument with an unrestricted universal conclusion is valid if and only if the premises entail an instance of the universal for an independent term. When arguments are stated in English, phrases like *let α be arbitrary* or *let us choose α arbitrarily* function as commitments to use the term α as an independent term.

The crucial part of this law is the *if* claim since the *only-if* part says only that a universal cannot be a valid conclusion unless any instance for an independent term is also valid, something that follows from the principle of universal instantiation. The key idea behind the truth of the *if* part is that, because the independent term α is unanalyzed and does not appear in either Γ

or θ , it could be made to refer to anything without affecting the premises Γ or the predicate θ . And this means that, if the premises suffice to entail $\theta\alpha$, they suffice to show that θ is true of everything—i.e., that the universal $\forall x \theta x$ is true. Indeed, given a proof of $\theta\alpha$ from the premises Γ , we could construct a proof of $\theta\tau$ for any term τ simply by replacing every occurrence of α by τ , our restrictions on α insuring that the premises Γ and θ remain unchanged and that α had no ties to them that are not shared by τ .

This argument recalls the comparison of the universal with conjunction. Since a conjunction can have any components, we must argue for each component individually and, since a conjunction has only two components, there is nothing to keep us from doing this. On the other hand, there would be no hope of providing a separate argument for each instance of a universal since, in general, there is no way of setting a limit on the number of instances it has. However, there is no need to consider each of these instances individually since they all have the same form, so an argument establishing an instance for one independent term can set the pattern for all of the rest.

A principle for the restricted universal as a conclusion follows from this law and the law for the conditional as a conclusion:

$\Gamma \Rightarrow (\forall x: \rho x) \theta x$ if and only if $\Gamma, \rho\alpha \Rightarrow \theta\alpha$ (where α is unanalyzed and does not appear in Γ, ρ , or θ)

That is, we can establish a restricted generalization by showing that an arbitrarily chosen object has the attribute when we assume that it is in the domain.

Glen Helman 28 Aug 2008

7.5.4. Adding instances

The implementation of the laws for universal quantifiers is fairly straightforward if we use derivations only in a positive way—i.e., use them only to show that entailments hold. Their use to show that entailments fail will be postponed until 7.7. We will consider only the unrestricted universal. Rules for restricted universals present no special difficulties and, indeed, can be seen as simply abbreviations for combinations of rules for the unrestricted universal and the conditional.

The exploitation rule for universals, which we will call *Universal Instantiation* (UI), is shown in Figure 7.5.4-2. It can be used to add any instance of the universal as a further resource, notating the universal to indicate the term for which an instance was added.

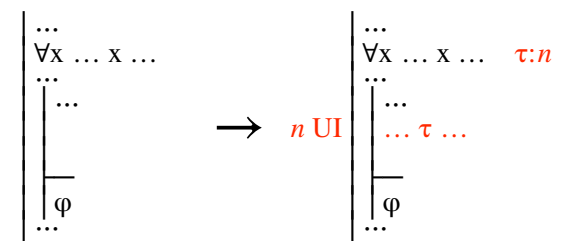

Fig. 7.5.4-2. Developing a derivation at stage n by exploiting an unrestricted universal for a term τ .

Although we record the use of this rule alongside the universal, the universal resource is not rendered completely inactive. The rule provides only a partial exploitation, extracting the content of the universal only for the single term τ . Since a universal does not bring with it any definite set of instances, it will never be rendered completely inactive, no matter how often this rule is used. Still, one use of the rule does exploit the universal for one term, and we record this by noting both the stage number and the term for which the universal has been exploited.

This information is used (much in the way we have used marking by stage numbers) to judge when a universal is *active for* a given term. To be active for a given term in a gap, a universal must be available in the gap and must not have been exploited for the term in the course of narrowing the gap. Specifically, an available universal is *inactive for* τ in a gap if it is marked by a pair $\tau:n$ and all scope lines to the left of some resource or goal entered at stage n continue unbroken to the left of the gap. Although an available universal is always active, it may not be active for all terms; and a term for which we apply the exploitation rule above should be one for which the universal is still active.

As we will see in 7.7.4, it is legitimate to limit the use of this rule to terms appearing in the available resources and goals the gap. These are the same terms from which we form alias sets and it will be enough to exploit a universal for at least one term from each alias set. But, occasionally, no terms will appear in the initial premises and conclusion and none will be introduced by other rules. When this is so, the exploitation rule above may be used to introduce a new unanalyzed term into the derivation.

For example, the premises and conclusion of the following derivation above contain no terms at all, so there would be no way of beginning it if we did not instantiate one of them for a new term.

	$\forall x Fx$	a:1
	$\forall x \neg Fx$	a:2
1 UI	Fa	(3)
2 UI	$\neg Fa$	(3)
	●	
3 Nc	\perp	

This is the only sort of case in which instances need be added for terms new to the gap being developed. The fact that we do so at all reflects the assumption built into our system that there is at least one reference value. The derivation above shows one consequence of this assumption—namely, that **Everything is finished** and **Everything is unfinished** are inconsistent. Clearly, if there is anything at all, then these two sentences cannot both be true. On the other hand, if we were to drop the assumption that there is something, both sentences could be true. For generalizations are false only when they have counterexamples; and, in a world in which there was nothing, there would be nothing to serve as a counterexample to either **Everything is finished** or **Everything is unfinished**. The assumption that there is something is perhaps the only assumption typically regarded as part of deductive logic that might be regarded as factual.

At the other extreme, use of this rule in case of generalizations containing functors may introduce new terms into the derivation, leading to new uses of the rule. For example, instantiating $\forall x P(fx)$ for the term a will give us $P(fa)$, which contains the term fa , and we may use this term also to instantiate the generalization, giving us $P(f(fa))$, which contains the term $f(fa)$ —and so on. As we will see in 7.7, this is one aspect of a general feature of the deductive logic for generalizations that will sometimes keep a derivation from ever reaching an end. That is not our concern now, but the possibility of going on forever in the application of rules shows that we can no longer wait to apply rules fully before checking to see if a gap closes. And, because a large number of applications of

instantiation may be possible, it is wise to select from among the terms with which we might instantiate a generalization those that seem most likely to help us close a gap.

The following derivation keeps universal instantiation to a minimum. Only the main quantifier is removed with each use of UI, so three uses are required to reach the bare predication $Rabc$. Only two more are needed to reach $Racc$ but three would have been required to reach a second predication, such as $Rccc$, that had a different term in the first place after R .

	$\forall x \forall y \forall z Rxyz$	a:1
1 UI	$\forall y \forall z Rayz$	b:2, c:4
2 UI	$\forall z Rabz$	c:3
3 UI	$Rabc$	(6)
4 UI	$\forall z Racz$	c:5
5 UI	$Racc$	(6)
6 Adj	$Rabc \wedge Racc$	(7)
	●	
7 QED	$Rabc \wedge Racc$	

On the other hand, a full use of instantiation for the terms appearing in the conclusion would have lead to $3 + 3 \times 3 + 3 \times 9 = 39$ uses of UI (i.e., three to exploit the premise for a , b , and c , three more exploitations for each of the three resources that result, and finally three more for each of the nine resources added in that way). A derivation is not damaged by extra uses of UI any more than it is damaged by using Ext to add conjuncts that are not needed later. But, while adding all conjuncts as resources whenever a conjunction was exploited presented no practical problem, using UI in all ways possible can lead to unmanageably large derivations in the case of even fairly simple premises.

Glen Helman 28 Aug 2008

7.5.5. General arguments in derivations

In order to manage general arguments in our system of derivations, we need a further sort of scope line. The portion of a derivation that constitutes a general argument will be marked by a scope line that is *flagged* by the independent term on which we generalize (as shown in Figure 7.5.5-1).

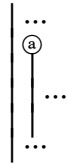

Fig. 7.5.5-1. A veil of ignorance flagged by the independent term a.

This flagging declares that the term is independent. Indeed, we will require that a term flagging a scope line appear only to its right, so the scope line will mark the scope of the term's use. In either form, the requirement is designed to insure that the independent term maintains no ties to the outside of the general argument so that, within the argument, it might refer to anything at all. For this reason, we will speak of a scope line flagged by a term as a *veil of ignorance*.

The limitation of the appearance of the independent term to the portion of the derivation marked by its scope line is more than is necessary to stay in accord with the laws for universals as conclusions. They require only that the term not appear in either the goal or the active resources of the gap that the vertical line spans, but we will never run short of terms and the stronger requirement is far easier to check.

Now, let us look at the planning rule for universal goals. It is known as *Universal Generalization* (UG) and is shown in 7.5.5-2.

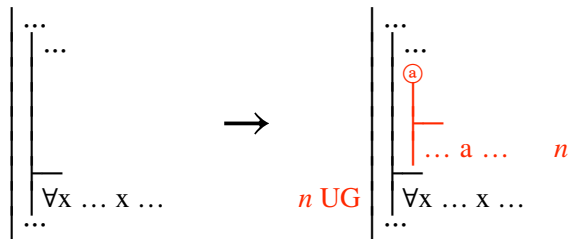
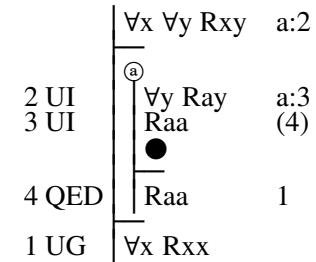

Fig. 7.5.5-2. Developing a derivation at stage *n* by planning for an unrestricted universal; the independent term *a* may be any unanalyzed term that is new to the derivation.

We try to reach our goal by a general argument, so we choose as our independent term an unanalyzed term *a* that is new to the derivation. An instance of $\forall x \theta x$ for the term *a* is the goal of the general argument, and further

development of the gap lies on the other side of a veil of ignorance concerning that independent term.

The short derivation shown below illustrates this rule. It shows that, if a relation *R* is universal in the sense of holding of any pair of things, then it is reflexive.



At the initial stage here, there is no vocabulary from which a term may be formed—and UI should be used to introduce new terms only as a last resort—so we apply the planning rule to the universal conclusion. After applying it, we have vocabulary for use with the exploitation rule, and we apply it twice for the term *a*. It would have been legitimate to exploit either universal resource for any other term τ as well, but that would not have contributed to closing the gap.

The following derivation illustrates the limitations on the scope of a term.

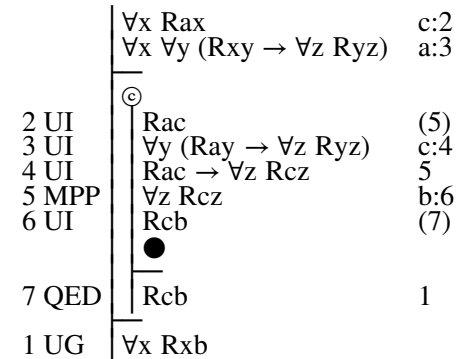

The independent term used here could not have been either *a* or *b* since both appear beyond the scope line of the general argument, one in a premise and the other in the conclusion.

The derivation shown here minimizes the use of UI, and the particular choice of instances needed to do this might not be obvious. Once the first premise is instantiated for *c*, the next two instantiations are designed to set up the use of MPP at stage 5; but that *c* is a better choice at stage 2 than, say, *b* is probably less obvious. It is fine to experiment, and there is no need to back up if you do not make the best choice. A derivation is never damaged by extra uses of UI; and, when we go on to use derivations to show the failure of entailments

involving generalizations in 7.7, we will require that, before a derivation can reach a dead end, any universal resource must be exploited for at least term from each alias set.

Glen Helman 28 Aug 2008

7.5.6. Syllogisms

We can now establish the validity of the forms of argument that are *syllogisms* in the narrower of the traditional senses of the term. Syllogisms in this sense are two-premised arguments whose component sentences are analyzed as restricted generalizations or their denials with quantified and restricting predicates that are unanalyzed. A syllogism must contain exactly three such predicates, and each of these predicates must appear in exactly two of the component sentences. The generalizations that are asserted or denied in the premises and conclusion can be affirmative or negative but all must be direct.

The constraints on predicates leave four possible *figures* distinguished by whether each of restricting or quantified predicates of the conclusion appears in the same or different role in the premise in which it also appears. For each choice of figure, there are $4 \times 4 \times 4 = 64$ *moods* reflecting the choice of a form of sentence (an assertion or denial of an affirmative or negative generalization). There are thus 256 syllogisms; and, of these, 15 are valid. This number is small enough that they could all be named. These names were constructed to display the mood of the syllogism in their choice of vowels and, in some of their consonants, ways of establishing the validity of some syllogisms on the basis of others.

Below is a derivation for the best known of these patterns. The name of this syllogism, *Barbara*, is one of the few that does not sound like the artificial construction it is.

	$\forall x (Mx \rightarrow Qx)$	a:5
	$\forall x (Rx \rightarrow Mx)$	a:3
	ⓐ	
		Ra (4)
3 UI		Ra → Ma 4
4 MPP		Ma (6)
5 UI		Ma → Qa 6
6 MPP		Qa (7)
		●
7 QED		Qa 2
2 CP		Ra → Qa 1
1 UG		$\forall x (Rx \rightarrow Qx)$

The letters chosen for predicates in the analysis are designed to highlight the figure. Notice that the restricting and quantified predicates of the conclusion (R and Q) play the same roles when they appear in the premises. The third predicate (M) is traditionally known as the *middle term*. An example is **All humans are mortal, All philosophers are human ⇒ All philosophers are**

mortal.

Middle terms do not always stand between the other two in the range of their application (as does **human** between **philosopher** and **mortal**); but, in all valid syllogisms, the middle term provides the basis for the relation between the other two predicates asserted in the conclusion and thus stands between them in this sense.

This derivation also provides an example of the form that will be taken by arguments involving restricted universals when they are reformulated using unrestricted quantifiers. Were we to have special rules for restricted universals, one kind of exploitation rule would have the effect of the sort of combination of UI and MPP seen in stages 3 and 4 and again in stages 5 and 6 above. The planning role for a restricted universal goal would have the effect of the sort of combination of UG and CP in stages 1 and 2; in short, it would introduce a general argument with a supposition that predicated the restricting predicate of the generalization to the independent term and a goal that predicated the quantified predicate.

Glen Helman 28 Aug 2008

7.5.s. Summary

- 1 The universal quantifiers and conjunction may both be used to say that each of a group of claims is true. This overlap in function indicates an analogy between these logical constants that can be seen also in the laws of entailment for them. The analogue to a component of a conjunction is an instance of a universal, in which the universal's quantified predicate is predicated a term. A universal is rarely equivalent to an actual conjunction of its instances, but for a given referential range **R**, it behaves like a possibly infinite conjunction of instances in a language enriched by adding the IDs of all values in **R**—i.e., it behaves like the conjunction of its instances in an expansion of the language by **R**. When we do not fix the range **R**, a universal $\forall x \theta x$ is not associated with any definite set of instances, but we still know that its instances $\theta \tau$ are all predications of θ ; and these two features are reflected in the laws of entailment for universals.
- 2 In the case of an unrestricted universal, we can state a principle of universal instantiation, which says that the universal implies each of its instances; and we may use this with the law for lemmas to get a law for this sort of universal as a premise.
- 3 We can describe the role of an unrestricted universal as a conclusion by using the idea of a general argument, in which an instance of a generalization is established in such a way that we may generalize from it to a universal claim. It is sufficient for an argument to be a general one that the term for which the instance is given not be compound, that it not appear in the premises, and that it not appear in the generalization we wish to conclude. Such a term is an independent term with respect to the argument. The law for the unrestricted conditional as a conclusion then tells us that we can conclude a universal from given premises when we can conclude an instance of it for an independent term.
- 4 The rule for exploiting universal resources—Universal Instantiation (UI)—should be used only for terms already appearing in the gap—provided there is at least one such term. The exploitation of universals can never be considered complete, and an available universal resource is always an active resource; but exploitation rules do render universals inactive for particular terms and should be applied only to terms for which the universal remains active.
- 5 In implementing the laws for universals as conclusions, we flag scope lines by terms that are being used as independent terms; such terms can appear only to the right of their scope lines. We plan for an unrestricted universal

goal by planning to use the rule Universal Generalization (UG). It directs us to set up a flagged scope line with an instance for the independent term as a new goal.

- 6 In its narrowest use, the term sylllogism refers to one of a group of 256 logical forms of two-premised arguments involving generalizations and their denials. A syllogism is traditional classified according to the roles in the premises of restricting and quantified predicates of the conclusion (its figure) and the logical form of each of the premises and conclusion (its mood). A syllogism contains one further predicate, the middle term, that, in a valid syllogism, provides the link between the predicates in the conclusion. The best known syllogism, named Barbara, is the only valid syllogism whose premises each assert an affirmative generalization.

Glen Helman 28 Aug 2008

7.5.x. Exercise questions

1. Give the instances of each of the following for the terms a, b, and c (remembering that you will drop the main quantifier, and only the main one, when giving an instance):
 - a. $\forall x Fx$
 - b. $\forall y Fy$
 - c. $\forall x Rxa$
 - d. $\forall x Saxb$
 - e. $\forall x \forall y Rxy$
 - f. $\forall x (Fx \rightarrow Gx)$
 - g. $\forall x (Fx \rightarrow Gd)$
 - h. $\forall x (Fx \rightarrow \forall y Rxy)$
 - i. $\forall x (Fx \rightarrow \forall x Rxx)$
2. Use the system of derivations to establish each of the following. You may use detachment and attachment rules.
 - a. $\forall x Fx, \forall x (Fx \rightarrow Gx) \Rightarrow Ga$
 - b. $\forall x (Fx \wedge Gx) \Rightarrow Fa \wedge Gb$
 - c. $\forall x Rxa, \forall x (Rbx \rightarrow Gx) \Rightarrow Ga$
 - d. $\forall x \forall y Rxy, \forall x (Rxx \rightarrow Gx) \Rightarrow Ga$
 - e. $\forall x \forall y Rxy \Rightarrow (Rab \wedge Rbb) \wedge Rca$
 - f. $\forall x Fx, \forall x (Fx \rightarrow Gx) \Rightarrow \forall x Gx$
 - g. $\forall x (Fx \wedge Gx) \Leftrightarrow \forall x Fx \wedge \forall x Gx$
 - h. $Fa \Leftrightarrow \forall x (x = a \rightarrow Fx)$
 - i. $\forall x \forall y Rxy \Rightarrow \forall y Rya$
 - j. $\forall x \forall y (Rxy \rightarrow \neg Ryx) \Rightarrow \forall x \neg Rxx$
 - k. $\forall x \forall y (gx = y \rightarrow Fy) \Rightarrow \forall x F(g(hx))$
3. In the following, certain alternative expressions are enclosed in brackets and separated by vertical bars. Choose one of each alternative pair of premises and one of each alternative pair of words or phrases in the conclusion so as to make a valid argument; then analyze the premises and conclusion and construct a derivation to show that the argument is valid. You may use detachment and attachment rules.
 - a. **Every road sign was colored**
 [Every stop sign was a road sign | Every road sign was a traffic marker]
 [If anything was red, it was colored | If anything was colored, it was painted]

 Every [stop sign | traffic marker] was [red | painted]

b. No road sign was colored

[Every stop sign was a road sign | Every road sign was a traffic marker]

[If anything was red, it was colored | If anything was colored, it was painted]

No [stop sign | traffic marker] was [red | painted]

c. Only road signs were colored

[Every stop sign was a road sign | Every road sign was a traffic marker]

[If anything was red, it was colored | If anything was colored, it was painted]

Only [stop signs | traffic markers] were [red | painted]

d. Among road signs all except colored ones were replaced

[Every stop sign was a road sign | Every road sign was a traffic marker]

[If anything was red, it was colored | If anything was colored, it was painted]

Among [stop signs | traffic markers] all except [red | painted] ones were replaced

For more exercises, use the [exercise machine](#).

Glen Helman 28 Aug 2008

7.5.xa. Exercise answers

		<i>instance for a</i>	<i>instance for b</i>	<i>instance for c</i>	
1.	a.	$\forall x Fx$	Fa	Fb	Fc
	b.	$\forall y Fy$	Fa	Fb	Fc
	c.	$\forall x Rxa$	Raa	Rba	Rca
	d.	$\forall x Saxb$	Saab	Sabb	Sacb
	e.	$\forall x \forall y Rxy$	$\forall y Ray$	$\forall y Rby$	$\forall y Rcy$
	f.	$\forall x (Fx \rightarrow Gx)$	$Fa \rightarrow Ga$	$Fb \rightarrow Gb$	$Fc \rightarrow Gc$
	g.	$\forall x (Fx \rightarrow Gd)$	$Fa \rightarrow Gd$	$Fb \rightarrow Gd$	$Fc \rightarrow Gd$
	h.	$\forall x (Fx \rightarrow \forall y Rxy)$	$Fa \rightarrow \forall y Ray$	$Fb \rightarrow \forall y Rby$	$Fc \rightarrow \forall y Rcy$
	i.	$\forall x (Fx \rightarrow \forall x Rxx)$	$Fa \rightarrow \forall x Rxx$	$Fb \rightarrow \forall x Rxx$	$Fc \rightarrow \forall x Rxx$
2.	a.	$\forall x Fx$	a:1		
		$\forall x (Fx \rightarrow Gx)$	a:2		
	1	UI	Fa	(3)	
	2	UI	$Fa \rightarrow Ga$	3	
	3	MPP	Ga	(4)	
		●			
	4	QED	Ga		
	b.	$\forall x (Fx \wedge Gx)$	a:1, b:3		
	1	UI	$Fa \wedge Ga$	2	
	2	Ext	Fa	(5)	
	2	Ext	Ga		
	3	UI	$Fb \wedge Gb$	4	
	4	Ext	Fb		
	4	Ext	Gb	(5)	
	5	Adj	$Fa \wedge Gb$	(6)	
		●			
	6	QED	$Fa \wedge Gb$		
	c.	$\forall x Rxa$	b:1		
		$\forall x (Rbx \rightarrow Gx)$	a:2		
	1	UI	Rba	(3)	
	2	UI	$Rba \rightarrow Ga$	3	
	3	MPP	Ga	(4)	
		●			
	4	QED	Ga		

d.	$\forall x \forall y Rxy$	a:1
	$\forall x (Rxx \rightarrow Gx)$	a:3
1 UI	$\forall y Ray$	a:2
2 UI	Raa	(4)
3 UI	Raa \rightarrow Ga	4
4 MPP	Ga	(5)
	●	
5 QED	Ga	

e.	$\forall x \forall y Rxy$	a:1, b:3
1 UI	$\forall y Ray$	b:2
2 UI	Rab	(5)
3 UI	$\forall y Rby$	b:4, a:6
4 UI	Rbb	(5)
5 Adj	Rab \wedge Rbb	X, (7)
6 UI	Rba	(7)
7 Adj	(Rab \wedge Rbb) \wedge Rba	X, (8)
	●	
8 QED	(Rab \wedge Rbb) \wedge Rba	

f.	$\forall x Fx$	a:2
	$\forall x (Fx \rightarrow Gx)$	a:3
2 UI	Fa	(4)
3 UI	Fa \rightarrow Ga	4
4 MPP	Ga	(5)
	●	
5 QED	Ga	1
1 UG	$\forall x Gx$	

g.	$\forall x (Fx \wedge Gx)$	a:3, b:7
3 UI	Fa \wedge Ga	4
4 Ext	Fa	
4 Ext	Ga	(5)
	●	
5 QED	Fa	2
2 UG	$\forall x Fx$	1
7 UI	Fb \wedge Gb	8
8 Ext	Fb	
8 Ext	Gb	(9)
	●	
9 QED	Gb	6
6 UG	$\forall x Gx$	1
1 Cnj	$\forall x Fx \wedge \forall x Gx$	

	$\forall x Fx \wedge \forall x Gx$	1
1 Ext	$\forall x Fx$	a:3
1 Ext	$\forall x Gx$	a:4
3 UI	Fa	(5)
4 UI	Ga	(5)
5 Adj	Fa \wedge Ga	X, (6)
	●	
6 QED	Fa \wedge Ga	2
2 UG	$\forall x (Fx \wedge Gx)$	

Reusing the term a as the independent term of the second general argument of the derivation on the left would have caused no logical problems since the two gaps are separate arguments boxed off from one another; however, we will hold to the simplest interpretation of the scope line and not allow terms flagging scope line to appear anywhere outside their indicated scope.

h.	Fa	(3)	$\forall x (x = a \rightarrow Fx)$	a:2
	ⓑ		$\neg Fa$	(3)
	b = a	a—b	a = a \rightarrow Fa	3
	●		$\neg a = a$	(4)
3 QED=	Fb	2	⊥	1
2 CP	b = a \rightarrow Fb	1	Fa	
1 UG	$\forall x (x = a \rightarrow Fx)$			

i.	$\forall x \forall y Rxy$	b:2
2 UI	$\forall y Rby$	a:3
3 UI	Rba	(4)
	●	
4 QED	Rba	1
1 UG	$\forall y Rya$	

Here the term a cannot be used as the independent term of the general argument because it already appears in the conclusion.

j.	$\forall x \forall y (Rxy \rightarrow \neg Ryx)$	a:3
	ⓐ	
	Raa	(5), (6)
3 UI	$\forall y (Ray \rightarrow \neg Rya)$	a:4
4 UI	Raa \rightarrow \neg Raa	5
5 MPP	\neg Raa	(6)
	●	
6 Nc	⊥	2
2 RAA	\neg Raa	1
1 UG	$\forall x \neg Rxx$	

k.	$\forall x \forall y (gx = y \rightarrow Fy)$	ha:2
	ⓐ	
2 UI	$\forall y (g(ha) = y \rightarrow Fy)$	g(ha):3
3 UI	g(ha) = g(ha) \rightarrow F(g(ha))	5
4 EC	g(ha) = g(ha)	X, (5)
5 MPP	F(g(ha))	(6)
	●	
6 QED	F(g(ha))	1
1 UG	$\forall x F(g(hx))$	

3. a. Every road sign was colored
 Every stop sign was a road sign
 If anything was colored, it was painted

Every stop sign was painted

	$\forall x (Dx \rightarrow Cx)$	a:5
	$\forall x (Sx \rightarrow Dx)$	a:3
	$\forall x (Cx \rightarrow Px)$	a:7
	\textcircled{a}	
	Sa	(4)
	Sa \rightarrow Da	4
3 UI	Da	(6)
4 MPP	Da \rightarrow Ca	6
5 UI	Ca	(8)
6 MPP	Ca \rightarrow Pa	8
7 UI	Pa	(9)
8 MPP	●	
	Pa	2
9 QED	Sa \rightarrow Pa	1
2 CP	$\forall x (Sx \rightarrow Px)$	
1 UG		

- b. No road sign was colored
 Every stop sign was a road sign
 If anything was red, it was colored

No stop sign was red

	$\forall x (Dx \rightarrow \neg Cx)$	a:5
	$\forall x (Sx \rightarrow Dx)$	a:3
	$\forall x (Rx \rightarrow Cx)$	a:7
	\textcircled{a}	
	Sa	(4)
	Sa \rightarrow Da	4
3 UI	Da	(6)
4 MPP	Da \rightarrow \neg Ca	6
5 UI	\neg Ca	(8)
6 MPP	Ra \rightarrow Ca	8
7 UI	\neg Ra	(9)
8 MTT	●	
	\neg Ra	2
9 QED	Sa \rightarrow \neg Ra	1
2 CP	$\forall x (Sx \rightarrow \neg Rx)$	
1 UG		

- c. Only road signs were colored
 Every road sign was a traffic marker
 If anything was red, it was colored

Only traffic markers were red

	$\forall x (\neg Dx \rightarrow \neg Cx)$	a:5
	$\forall x (Dx \rightarrow Mx)$	a:3
	$\forall x (Rx \rightarrow Cx)$	a:7
	\textcircled{a}	
	\neg Ma	(4)
	Da \rightarrow Ma	4
3 UI	\neg Da	(6)
4 MTT	\neg Da \rightarrow \neg Ca	6
5 UI	\neg Ca	(8)
6 MPP	Ra \rightarrow Ca	8
7 UI	\neg Ra	(9)
8 MTT	●	
	\neg Ra	2
9 QED	\neg Ma \rightarrow \neg Ra	1
2 CP	$\forall x (\neg Mx \rightarrow \neg Rx)$	
1 UG		

- d. Among road signs, all except colored ones were replaced
 Every stop sign was a road sign
 If anything was colored, it was painted

Among stop signs, all except painted ones were replaced

	$\forall x ((Dx \wedge \neg Cx) \rightarrow Lx)$	a:8
	$\forall x (Sx \rightarrow Dx)$	a:4
	$\forall x (Cx \rightarrow Px)$	a:6
	\textcircled{a}	
	Sa \wedge \neg Pa	3
	Sa	(5)
3 Ext	\neg Pa	(7)
3 Ext	Sa \rightarrow Da	5
4 UI	Da	(9)
5 MPP	Ca \rightarrow Pa	7
6 UI	\neg Ca	(9)
7 MTT	(Da \wedge \neg Ca) \rightarrow La	10
8 UI	Da \wedge \neg Ca	X, (10)
9 Adj	La	(11)
10 MPP	●	
	La	2
11 QED	(Sa \wedge \neg Pa) \rightarrow La	1
2 CP	$\forall x ((Sx \wedge \neg Px) \rightarrow Lx)$	
1 UG		