

# 7.8. Finite & infinite structures

## 7.8.0. Overview

Many arguments that generate unending derivations have counterexamples that use only finitely many reference values. But, although the rules can be modified to uncover such counterexamples, this is not enough to insure decisiveness.

### 7.8.1. Finding finite structures

We can search for finite counterexamples by modifying rules to consider old terms along with new ones or to consider the possibility that new terms are co-aliases of old ones.

### 7.8.2. The failure of decisiveness

We cannot hope to find counterexamples in this way for all invalid arguments because the counterexamples to some invalid arguments always have infinite ranges.

Glen Helman 13 Nov 2004

## 7.8.1. Finding finite structures

To complete the discussion of the adequacy of the system of derivations for generalizations, we will look a little more closely at the reasons why it is not decisive. There are two aspects to the problem, one concerning universals alone and another concerning their interaction with functors. The infinitely developing derivations displayed earlier are enough to show us that our system is not decisive, but the failure of decisiveness in these derivations does not run very deep and can be overcome by a relatively small adjustment to our rules. Different adjustments are needed to handle universals and functors, and we will consider the case of universals first.

Our current rules direct us to reach a universal goal  $\forall x \theta x$  by trying to close a gap whose goal is an instance  $\theta a$  for some parameter  $a$ . Although we need to close such a gap to show that the universal goal can be reached, this gap need not point us toward the only way of dividing the original gap. When we are constructing general arguments we are looking for counterexamples to generalizations. Thus, for a general argument to go through, we must show that there is no counterexample of any sort; it is not enough to show that the things we are already speaking of are not counterexamples. However, to show that a general argument fails, a counterexample of any sort, new or old, will do; and a structure dividing a gap between resources and an instance of the universal for an old term would be enough to show that the universal is not entailed by those resources. This means that, in a negative use of derivations, there is some reason for considering gaps whose goals are instances for old terms. We can refine our analysis of entailment to take account of this by making the planning rules for universals more elaborate. The alteration makes derivations cumbersome in practice but it can help to focus attention on deeper reasons for failure of decisiveness.

The revised rules are **Supplemented Universal Generalization** (UG+) and **Supplemented Restricted Universal Generalization** (RUG+); they are shown in Figure 7.8.1-1.

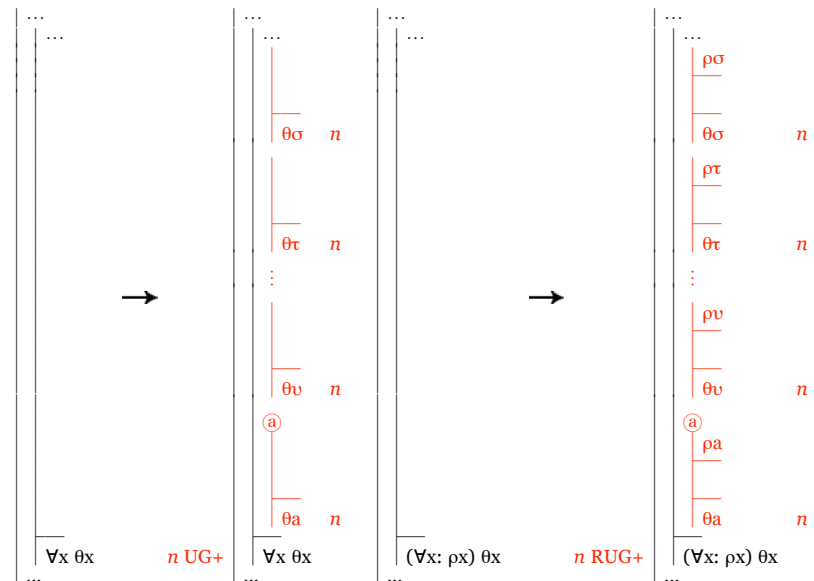
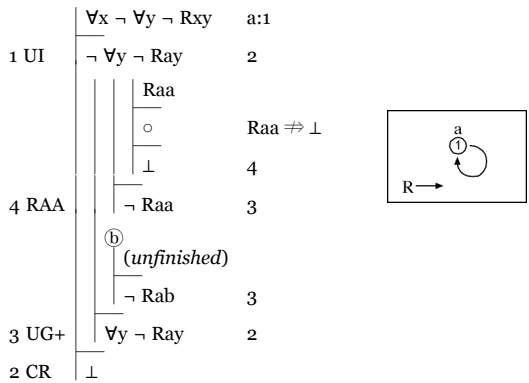

Fig. 7.8.1-1. Developing a derivation at stage  $n$  by planning for an unrestricted or restricted universal; the parameter  $a$  is new to the derivation and the terms  $\sigma, \tau, \dots, u$  include at least one from each current alias set for the gap.

We alter the rules UG and RUG by adding further new gaps in which we try to conclude instances of the universal not only for a new term but also for terms already appearing in the gap. Adding these new gaps will certainly make it no easier to show that an entailment holds. And they make it no harder either, since anything that can be shown for the parameter a can be shown for any term. Their function is instead to help us show that an entailment fails while using as few terms as possible. The new gaps provide new directions in which we may search for a path that not only remains open but reaches a dead end.

The derivation below shows the effect of the first rule when it is applied to our earlier example. The first gap in this derivation has reached a dead end. Its only active resources are the initial premise and Raa, and neither is exploitable. In the case of the universal premise, this is because it has already been exploited for the term a, which is the only term ever appearing in this gap.



The gap describes a structure whose referential range contains one value, and the predicate R will be true of the pair consisting of this value and itself. The initial premise—which says that there is no value that is related to nothing by R—is thus true in this structure, showing that the *reductio* entailment  $\forall x \neg \forall y \neg Rxy \Rightarrow \perp$  fails.

A planning rule for universal goals is one way we can be led to introduce and unending series of terms. Another way appears when a universal quantifier binds a variable occurring in a compound term. When such a generalization is instantiated, a new compound terms can be introduced into the derivation, leading to still further instantiation. We could avoid such further instantiation if the new compound term was in the same alias set as a term for which the universal had already been instantiated, so we can investigate the possibility of avoiding an infinitely developing gap by trying to put new compound terms in already existing alias sets. On this approach, when we introduce a new compound term that does not automatically become part of an already existing alias set, we also look at ways of identifying the new compound term with existing terms, at least one from each alias set. We will say that in doing this we are **securing** the term. Of course, it may be that no identification with existing terms is consistent with our resources. We allow for this possibility by adding a gap in which we make no assumptions about the new term.

The rule shown in Figure 7.8.1-2 can be used to sure terms. We suppose in turn that a compound term is a co-alias of each of a series of unanalyzed terms already in the gap and also pursue the development of the gap without new assumptions. Fullest investigation of the possibilities comes if we include at least one unanalyzed term from each alias set containing such terms. We will call this rule **Securing a Term** (ST).

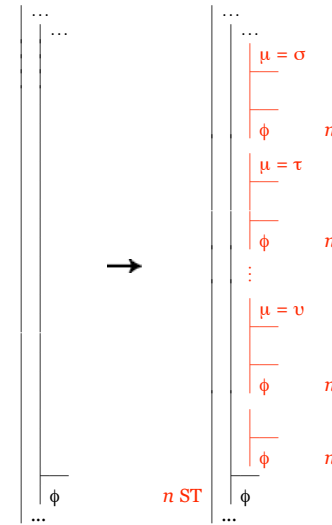
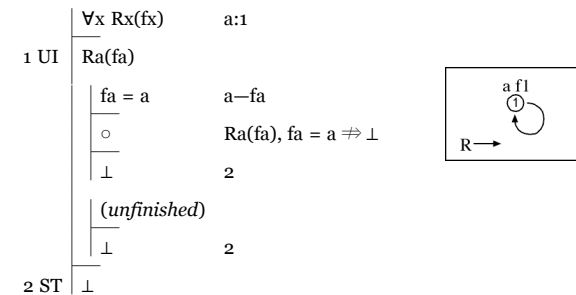

Fig. 7.8.1-2. Developing a derivation at stage  $n$  by securing a compound term  $\mu$ ; the terms  $\sigma, \tau, \dots, u$  include at least one from each current alias set for the gap.

Although the application of this rule would often be quite awkward, it makes short work of the first of our examples of infinitely developing derivations.



Having introduced the term fa through the instantiation at stage 1, we have the alias sets {a} and {fa}. We consider securing fa by identifying it with the term a. The first gap has then reached a dead end because the universal has already been exploited for a member of its single alias set. There is a second unfinished gap that merely represents the continuation of the gap after stage 1 with no added assumption about the identity of the term fa. The structure described by the dead-end gap is one whose range has a single member named by the term a, which stands in the relation R to itself. The single reference value of this structure is the only possible input and output for the functor f.

## 7.8.2. The failure of decisiveness

The rules UG+, RUG+, and ST are designed to uncover finite structures whenever possible. We will not look at arguments which show that they do this; instead we will see why finite structures are not always there to be uncovered.

For example, consider the following pair of sentences:

$$\forall x \forall y \forall z ((Rxy \wedge Ryz) \rightarrow Rxz) \\ \forall x \neg Rxx$$

The first says that the relation expressed by R obeys a law of transitivity, and the second says that nothing is related to itself by R, which is to say that R is *irreflexive*.

What must a structure be like to make these sentences true? Thinking in terms of the diagrams of 6.4.2, the claim of irreflexivity tells us that there cannot be any looped arrows. The claim of transitivity tells us that arrows linked head to tail running from object a to object b and from object b to object c can be spanned by an arrow running directly from a to c (see Figure 7.8.2-1).

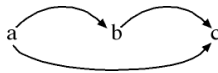

Fig. 7.8.2-1. The arrow spanning two linked arrows that is implied by transitivity.

Now, if we had a circuit of arrows leading from some object back to itself by way of other objects, transitivity would imply that there was a loop leading from the object directly back to itself (as in Figure 7.8.2-2). Irreflexivity would rule this out, so the two can be true together only if there are no loops or circuits of arrows.

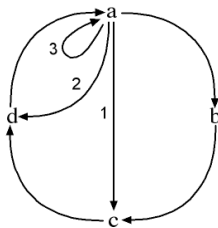

Fig. 7.8.2-2. A circuit from a to a reduced to a looped arrow in three steps by spanning linked arrows.

Finally, let us add to both either of the sentences  $\forall x \neg \forall y \neg Rxy$  and  $\forall x$

$Rx(fx)$  that we considered in 7.8.1. Each of the latter sentences tells us, in its own way, that every object is at the tail of some arrow. A little thought (and attempts at diagrams) will show that there is no way to manage this with a finite number of objects unless there is somewhere a loop or a circuit of arrows. So, although the sentences  $\forall x \neg \forall y \neg Rxy$  and  $\forall x Rx(fx)$  can each be made true in a structure with only one reference value if we consider them by themselves, they cannot be true along with claims of transitivity and irreflexivity in any structure with only a finite number of values.

Nevertheless  $\forall x \neg \forall y \neg Rxy$  and  $\forall x Rx(fx)$  are consistent with claims of transitivity and irreflexivity. For example, let us take the positive integers as our referential range and let R express the relation < of one number being less than another. The relation < is transitive and irreflexive. Moreover, each positive integer is less than some positive integer, so there is no positive integer that has the property of being less than no positive integer—and that is what  $\forall x \neg \forall y \neg Rxy$  says on this interpretation. And, if we interpret the functor f by any function whose output is always larger than its input,  $\forall x Rx(fx)$  will also be true.

So there are sets of sentences that are consistent but whose members cannot all be true with only a finite range of referential values. This means that, even if a revised system of derivations using UG+, RUG+, and ST always succeeds in locating finite structures, it cannot always provide an answer to our questions about entailment. If the entailment holds, it will say so. If the entailment fails and can be shown to fail using a finite structure, it will say so. But, if the entailment fails and can only be shown to fail only by using an infinite structure, it will give no answer because it will never finish describing a structure of the required sort.

Of course, it is possible to describe an infinite structure in a finite space (as we did informally above), so we might hope that a more substantial modification of our system might lead us to descriptions of infinite structures after finitely many stages. But here we must recall the result of Church mentioned earlier: although an improved system might provide answers to some further questions about entailment, no system could answer them all correctly. In terms of the present discussion, this implies that no matter what method we choose for describing structures, there are bound to be structures among those we need to describe that will still elude us.

## 7.8.s. Summary

Our system is not decisive in part because we always look to new parameters as possible counterexamples to a generalization and assume that terms are not co-aliases unless our resources tell us otherwise. But, while we must consider new terms as possible counterexamples and we must allow for the possibility that terms not made co-aliases refer to different things, we may also consider alternatives that point toward smaller structures. The rules [Supplemented Universal Generalization \(UG+\)](#) and [Supplemented Restricted Universal Generalization \(RUG+\)](#) leads us to consider instances for old as well as new terms when planning for a generalization. And we can [secure](#) new compound terms as co-aliases of unanalyzed terms by using the rule [Securing a Term \(ST\)](#).

Even with these rules, we cannot always reach dead-end gaps when derivations fail because dead-end gaps describe finite structures, and invalid arguments are not always divided by finite structures. There are some sets of sentences whose members can be made all true only with an infinite range of reference values. One example consists of sentences saying that a predicate R expresses a relation that is [irreflexive](#) and transitive and is such that each reference value stands in this relation to some reference value. No system like ours could drive a gap to a dead end in such cases and, while a very different system might do better in some of them, it has been shown that no system could do so in all such cases.

Glen Helman 13 Nov 2004

## 7.8.x. Exercise questions

Use the system of derivations to find structures dividing premises from conclusions in the cases below. You will need to use the rule UG+.

1.  $\forall x \neg \forall y \neg Rxy / \forall x \neg Rxx$
2.  $\forall x \neg \forall y Rxy / \neg \forall x Rxa$
3.  $\forall x \neg \forall y Rxy / \forall x \neg Rax$

Glen Helman 01 Aug 2004

### 7.8.xa. Exercise answers

1.

	$\forall x \neg \forall y \neg Rxy$	a:3
3 UI	$\begin{array}{ l} \textcircled{a} \\ \hline Raa \\ \hline \neg \forall y \neg Ray \\ \hline Raa \\ \hline \circ \\ \hline \perp \end{array}$	4
6 RAA	$\begin{array}{ l} \hline \neg Raa \\ \hline \textcircled{b} \\ \hline \neg Rab \\ \hline \forall y \neg Ray \\ \hline \perp \\ \hline \neg Raa \\ \hline \forall x \neg Rxx \end{array}$	5
5 UG+		4
4 CR		2
2 RAA		1
1 UG		

$Raa \Rightarrow \perp$

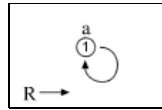

from the 1st open gap  
(the 2nd is not fully developed)

2.

	$\forall x \neg \forall y Rxy$	a:2, b:8
2 UI	$\forall x Rxa$	a:3, b:9
3 UI	$\begin{array}{ l} \neg \forall y Ray \\ \hline Raa \\ \hline \bullet \\ \hline Raa \\ \hline \textcircled{b} \\ \hline \neg Rab \\ \hline \neg \forall y Rby \\ \hline Rba \\ \hline \bullet \\ \hline \neg Rbb \\ \hline \circ \\ \hline \perp \\ \hline Rbb \\ \hline \textcircled{c} \\ \hline Rbc \\ \hline \forall y Rby \\ \hline \perp \\ \hline Rab \\ \hline \forall y Ray \\ \hline \perp \\ \hline \neg \forall x Rxa \end{array}$	4 (6)
6 QED		5
8 UI		10
9 UI		(12)
12 QED		11
13 IP		11
11 UG+		10
10 CR		7
7 IP		5
5 UG+		4
4 CR		1
1 RAA		

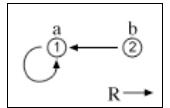

from the 1st  
open gap  
(the 2nd is not  
fully developed)

3.

	$\forall x \neg \forall y Rxy$	a:3, c:8
	Raa	(6)
3 UI	$\neg \forall y Ray$	4
	•	
6 QED	Raa	5
	(c)	
	$\neg Rac$	
8 UI	$\neg \forall y Rcy$	9
	$\neg Rca$	
	○	Raa, $\neg Rac, \neg Rca \Rightarrow \perp$
	$\perp$	11
11 IP	Rca	10
	$\neg Rcc$	
	○	Raa, $\neg Rac, \neg Rcc \Rightarrow \perp$
	$\perp$	12
12 IP	Rcc	10
	(d) (unfinished)	
	Rcd	10
10 UG+	$\forall y Rcy$	9
9 CR	$\perp$	7
7 IP	Rac	5
5 UG+	$\forall y Ray$	4
4 CR	$\perp$	2
2 RAA	$\neg Raa$	1
	(b) (unfinished)	
	$\neg Rab$	1
1 UG+	$\forall x \neg Rax$	

