

4.2.3. Further examples

Both disjunction rules are illustrated by the derivation at the right, in which one grouping of a three-part disjunction is shown to entail the other. Choices between the two ways of planning for a goal disjunction were made at stages 2, 3, 5, 6, and 7 in accordance with the rules of thumb given earlier. The way each choice was made helped to shorten the derivation —though in each case only by a few steps. This derivation is contrived to provide several examples of PE; instead we might have planned for the initial goal at stage 1 before exploiting the premise rather than planning for it separately in each of three gaps.

		$A \vee (B \vee C)$	1
		A	(4)
		$\neg C$	
		$\neg B$	
		•	
4 QED		A	3
3 PE		$A \vee B$	2
2 PE		$(A \vee B) \vee C$	1
		$B \vee C$	5
		B	(8)
		$\neg C$	
		$\neg A$	
		•	
8 QED		B	7
7 PE		$A \vee B$	6
6 PE		$(A \vee B) \vee C$	5
		C	(10)
		$\neg (A \vee B)$	
		•	
10 QED		C	9
9 PE		$(A \vee B) \vee C$	5
5 PC		$(A \vee B) \vee C$	1
1 PC		$(A \vee B) \vee C$	

The scale of the difference you can expect to result from a choice between the two forms of PE is illustrated by the two derivations below.

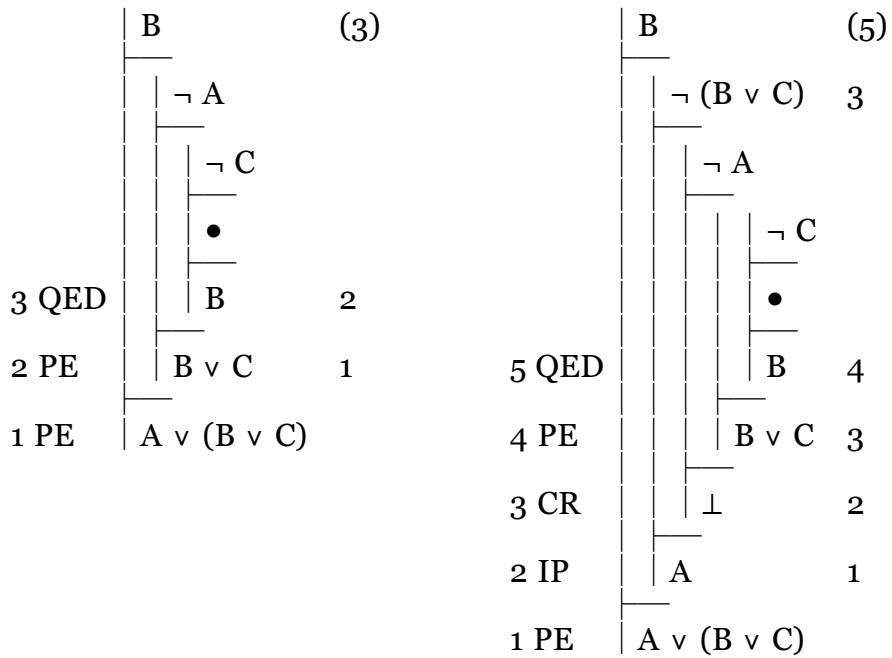

Each chooses a different way of planning for the initial goal at stage 1. Notice that in the second, which makes the less efficient choice, we are led back to the goal $B \vee C$ in a couple of stages.